

CATALOGUE OF INSTRUMENTAL TESTS

SPECIALIZED CONSULTING AND RESEARCH LABORATORY

Skin Lab
P. S. A.



Find out more at
www.skinlab.pl



SKINLAB P.S.A. is a dynamically developing consulting company that is providing research and regulatory services, including EU Responsible Person. SKINLAB P.S.A. is a modern research center in which:

We perform various types of dermatological tests, application tests and instrumental tests.	We offer consultation on selecting appropriate marketing claims.	We advice on cosmetic product labeling.
The tests are conducted in specially equipped laboratories.	We prepare documents in accordance with REACH and CLP.	We perform all tests required to complete the Safety Assessment Report.
We have our own Institute of Dermatology which oversees research and analysis.	We register the product on the SCPNP, PC portal.	We provide tests supervised by: dermatologist, ophthalmologist, pediatrician, gynecologist, trichologist.

The main objective of the SKINLAB P.S.A. laboratory is to confirm the safety, quality, and effectiveness of:

cosmetic
products

chemical
products

detergent
products

nutritional
supplements

We guarantee complete professionalism, objectivity and confidentiality in providing our services.



VISIOFACE® RD

The device enables comprehensive facial photography. Thanks to stable and uniform lighting provided by 210 white LEDs, it is an ideal tool for conducting research on the effectiveness of cosmetic products.

The station with LED lighting and a high-quality camera takes detailed images of the face in a frontal or lateral position, with the ability to compare photographs before and after the use of a cosmetic product.

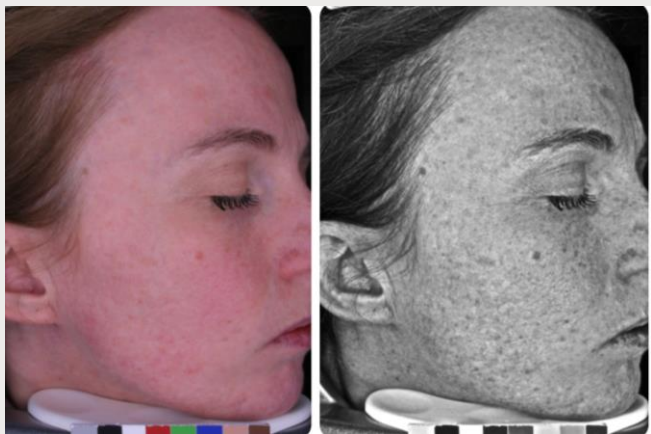
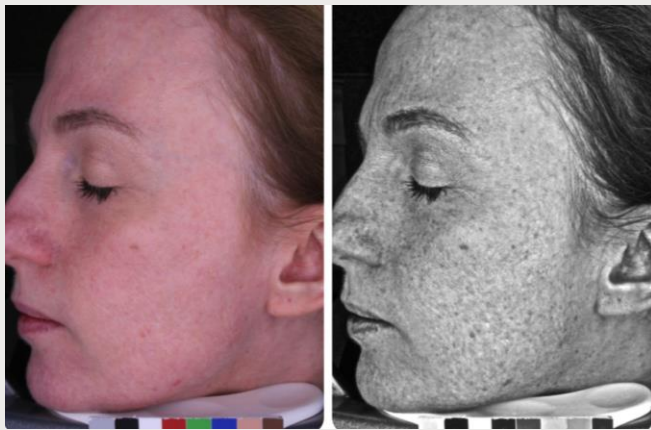

SKIN ANGING MAP

This provides a visual map of the skin, highlighting areas affected by long-term exposure to ultraviolet (UV) radiation. The analysis relies on specialized lighting and image processing algorithms that reveal changes invisible to the naked eye.

The result is presented as a graphical map, where color intensity corresponds to the degree of damage- **the higher the intensity, the greater the severity of photoaging.**



SKIN REACTIVITY

Skin with high reactivity (often referred to as sensitive skin) shows a faster and more intense response to stimulation compared to skin with normal reactivity. The device analyzes color distribution, with particular attention to the red scale, enabling precise **visualization of skin sensitivity** levels even in areas not visible during standard observation.



ACNE LESSIONS

The assessment of acne lesions provides a precise visualization of the skin and identifies skin imperfections. This analysis allows for monitoring the product's **effectiveness in reducing acne lesions**, providing objective data for evaluating the cosmetic's efficacy.



VISIBILITY AND DISTRIBUTION OF WRINKLES- WHOLE FACE PHOTOGRAPHY

The assessment of acne lesions enables precise imaging of the skin and identification of skin imperfections. This analysis allows for monitoring the product's **effectiveness in reducing acne lesions**, providing objective results for evaluating the cosmetic's efficacy.



PIGMENTATION UNIFORMITY INDEX

This parameter refers to the degree of skin tone uniformity in the analyzed facial area. It is assessed using the ΔE index. As part of the analysis, measurements are taken at five selected random points, based on which the color variation value is determined.

A low ΔE value indicates a **high degree of skin tone unevenness**. Elevated values indicate increased color variation and the presence of more pronounced color differences within the analyzed area.



COMPREHENSIVE FACIAL ANALYSIS

The analysis involves comparing whole-face photographs taken under equal lighting conditions before and after a specified period of product use. The study includes an assessment of important skin parameters, including:

- ✓ the size and visibility of skin pores
- ✓ absence of acne lesions
- ✓ the presence of wrinkles
- ✓ evening out of skin tone

Based on the results obtained, it is possible to comprehensively evaluate the product's effectiveness in these areas.

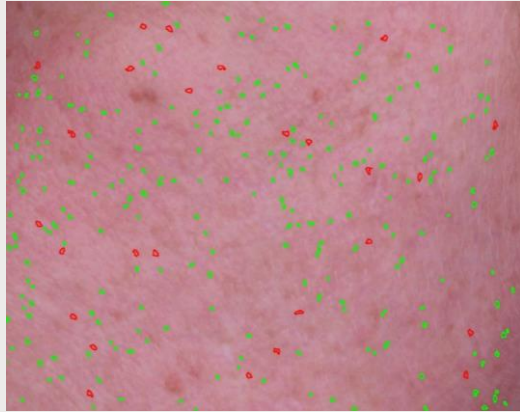

NON-COMEDOGENIC

The equipment enables the detection and quantitative assessment of the percentage of pore surface area, distinguishing between enlarged pores (marked in red) and fine pores (marked in green).

The test allows for the assessment of the comedogenic potential of the analyzed cosmetic product, including confirmation that the analyzed cosmetic product exhibits no comedogenic properties (**does not clog pores**).

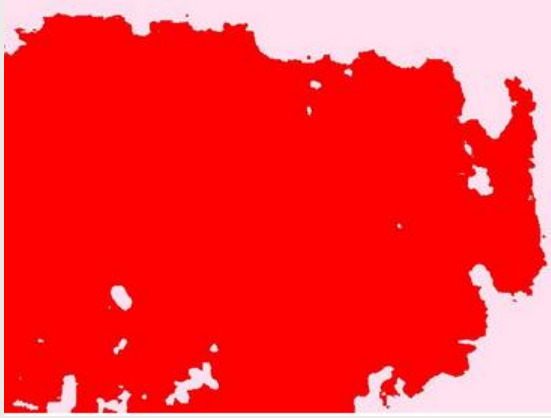

Microphotography taken using polarized light at 30x magnification.

SEBUM

The test is performed using a SEBUM STRIP. It allows for objective verification of the effectiveness of cosmetic products in terms of:

- ✓ reducing sebum secretion
- ✓ reducing skin oiliness

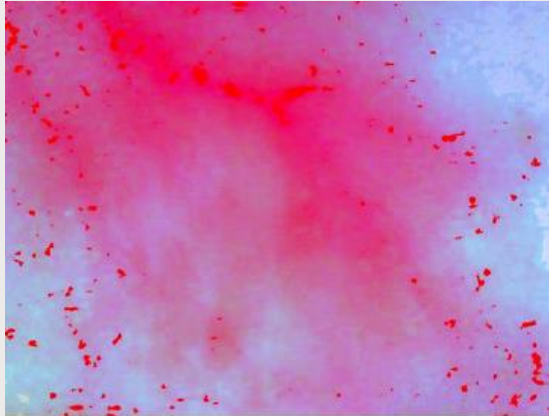

Microphotography taken using polarized light at 30x magnification.

SKIN SENSITIVITY

Performing skin sensitivity tests allows to confirm the declared effects of the product, including:

- ✓ suitable for sensitive skin
- ✓ reduces skin hypersensitivity (reactivity)

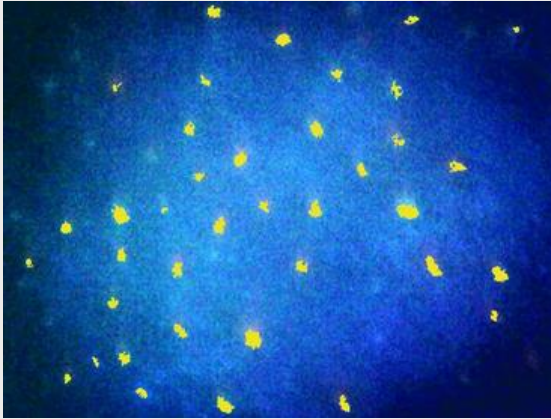

Microphotography taken using UV light at 30x magnification.

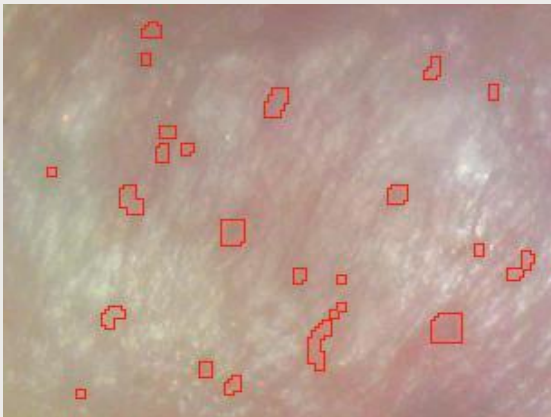

Microphotography of skin taken using diffused light at 30x magnification.

INFLAMMATION/ACNE

The test allows to determine the number of skin inflammations, including acne lesions in a specific area of the skin. The results obtained during the test confirm the declared effects of the product, such as:

- ✓ reduction of inflammation (acne lesions)
- ✓ reduction in the number of blemishes and papules
- ✓ improvement in the overall condition of problematic and acne-prone skin

PORE ANALYSIS

It allows the size of pores to be measured and the number of pores in the analyzed skin area to be determined. The results confirm the product's effectiveness in **reducing the number of pores.**

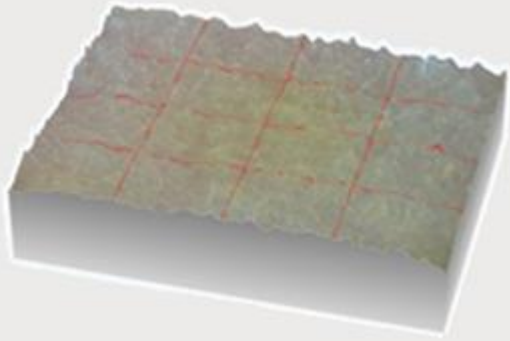

Microphotography of skin taken at a resolution of 1280 x 1024.

3D SKIN STRUCTURE

Skin texture analysis, which involves assessing the degree of roughness reduction, confirms the declared **skin smoothing effect** (reduction of roughness).

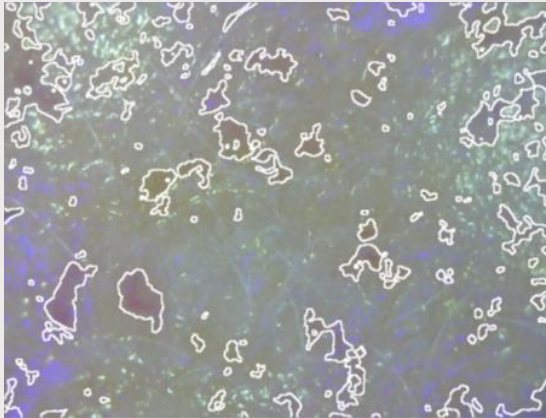

Microphotography of skin taken using UV light at a resolution of 1280 x 1024.

VASCULAR LESIONS/ TELANGIECTASIA

The test for vascular lesions is performed using UV diodes. The test can confirm, among other claims:

- ✓ reduces the number of vessels
- ✓ reduces fine spider veins
- ✓ the skin looks more uniform

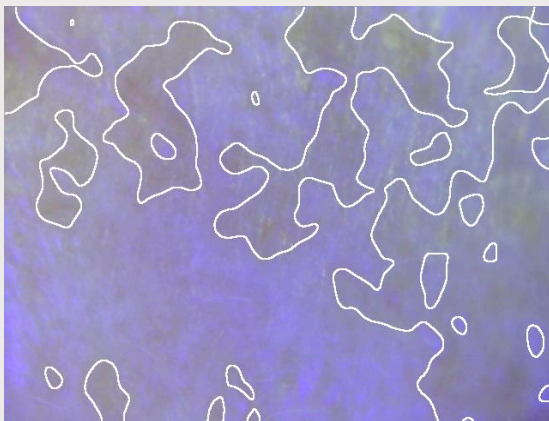

Microphotography of skin taken using UV light at a resolution of 1280 x 1024.

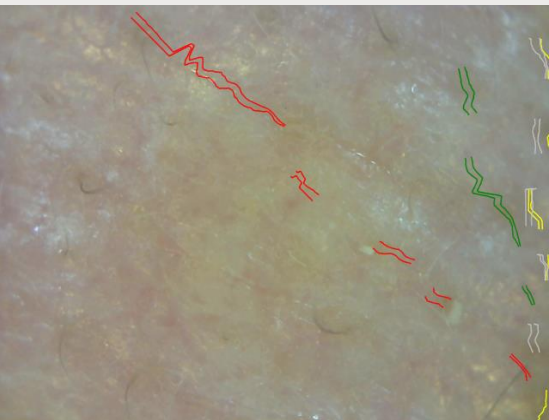

Microphotography of skin taken at a resolution of 1280 x 1024.

DISCOLORATION

Test performed using UV light. Discoloration is presented as a percentage (%). The intensity of discoloration saturation is determined. Test allows to confirm the declared effects of the product, including:

- ✓ evening out and improving skin tone
- ✓ reducing the area and intensity of discoloration

WRINKLE ANALYSIS

It provides a precise measurement of their width, expressed in millimeters [mm]. Based on the results obtained, the device classifies wrinkles according to their depth (shallow, medium, deep). The analysis allows for objective confirmation of the effectiveness of the treatment and verification of claims **regarding wrinkle reduction.**



Microphotography of the skin taken using CORNEUM STRIP.

SKIN EXFOLIATION

This parameter measures the level of dead cells, i.e., the degree of exfoliation of the stratum corneum. The test allows to determine whether the skin is being cared for properly. The test is performed using a CORNEUM STRIP pad. Test allows to confirm the declared effects of the product, including:

- ✓ improvement of skin condition through exfoliation
- ✓ reduction of skin flaking

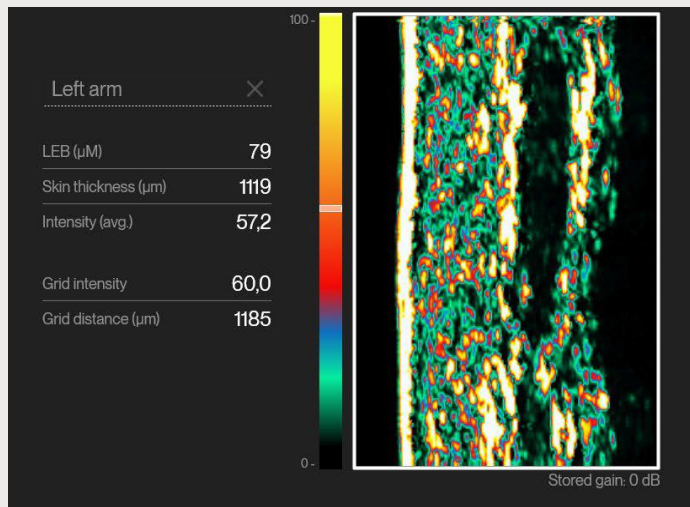
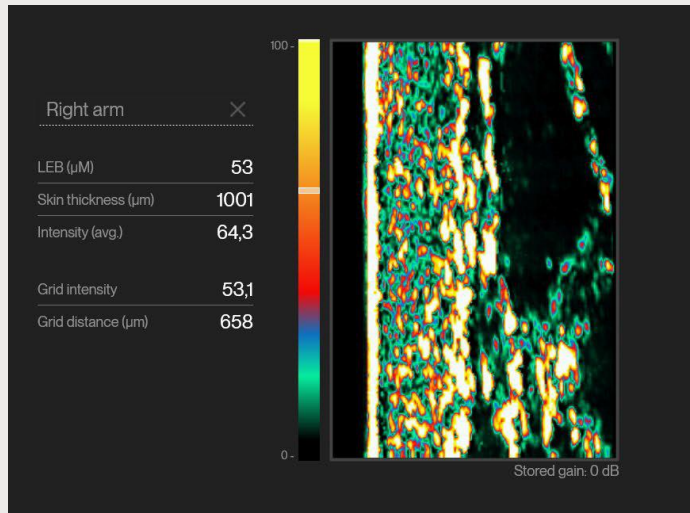

ULTRASOUND PROBE

A standard ultrasound probe allows the density of the dermis to be measured by analyzing the echogenicity of the ultrasound image, which indirectly correlates with the content and organization of collagen fibers.

Automatic assessment of the SLEB band- parameter related to skin photodamage and the severity of sun-induced changes.

Precise measurement of skin thickness (epidermis and dermis)

The results obtained allow for objective confirmation of the effectiveness of the tested product in terms of:

- ✓ improving skin collagen
- ✓ increasing skin thickness
- ✓ reducing signs of photoaging of the skin
- ✓ reducing visible sun damage

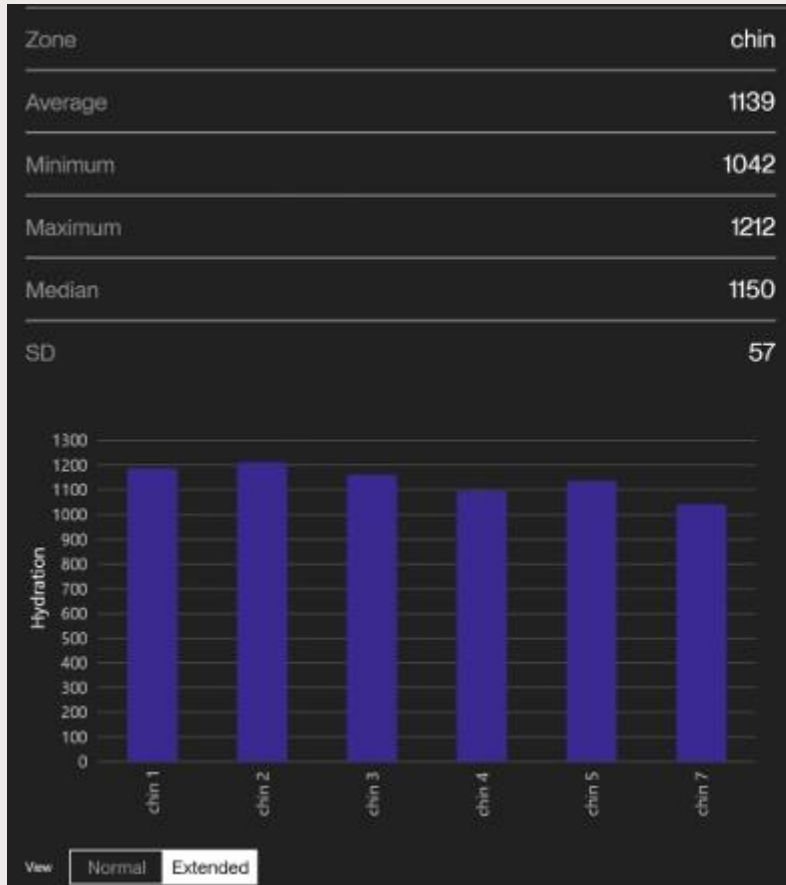

MOISTURIZATION

The PIN probe for measuring skin moisturization, used in DermaLab Combo devices, works by measuring the electrical conductivity of the skin, which varies depending on the water content in the stratum corneum. Electrical conductivity analysis allows for a quantitative assessment of skin moisturization levels. Measuring skin moisturization allows for the assessment of both the immediate effect of the product and the maintenance of moisturization levels over time, expressed as a percentage change (%) relative to the baseline value.

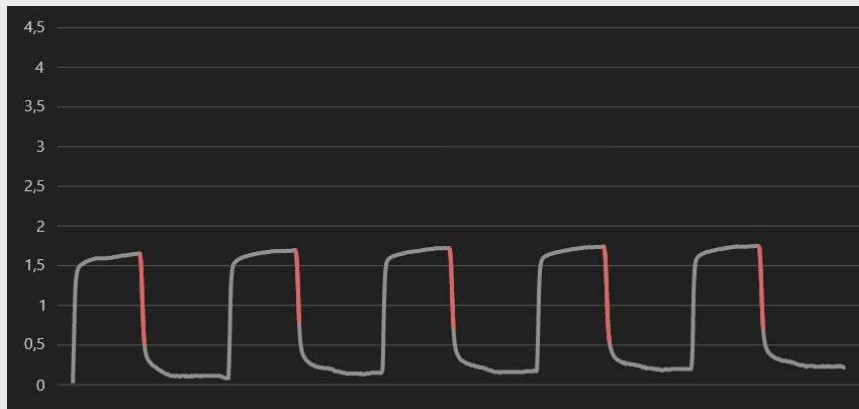
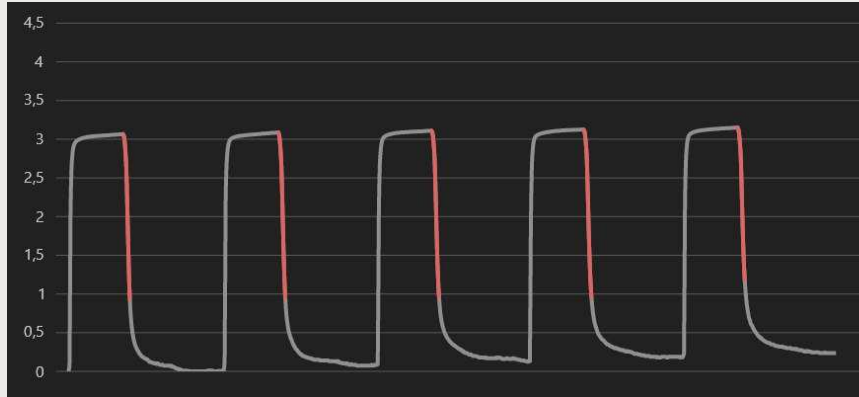

ELASTICITY

The elasticity probe in DermaLab Combo assesses the viscoelastic properties of the skin using the suction method. A controlled vacuum is created, which lifts the skin, and then analyzes how high the skin rose and how quickly it returned to its original position. On this basis, the device assesses the elasticity and resilience of the skin. Measuring skin elasticity allows you to determine the percentage improvement in skin elasticity expressed as a percentage (%).

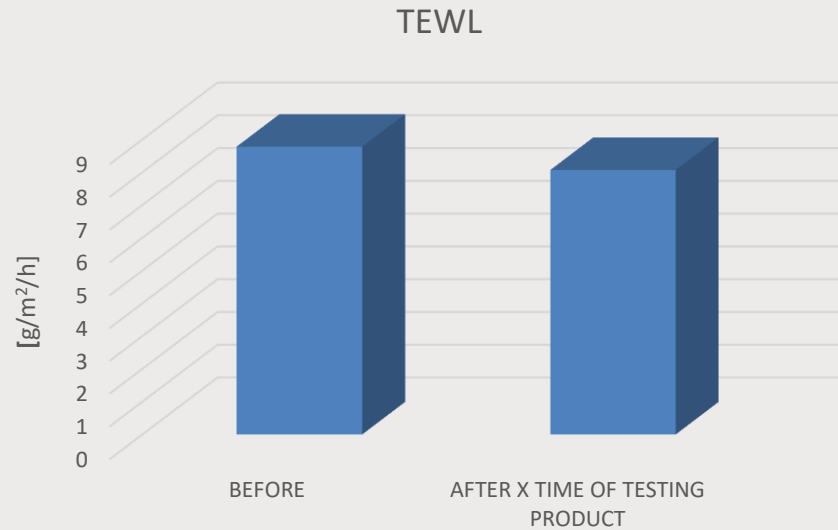

TEWL (TRANSEPIDERMAL WATER LOSS)

The device records the difference in water steam concentration between two probes placed at a specific distance from the skin. Based on this, the TEWL value is calculated, expressed in units of g/m²/h (grams of water per square meter of skin per hour). The test confirms the declared effects of the product:

- ✓ supporting the protective barrier function
- ✓ reducing transepidermal water loss
- ✓ improving the integrity of the epidermal barrier

COLORIMETRIC PROBE

Used to assess skin parameters such as erythema, melanin, and gloss. Color measurement is based on the diffuse reflectance spectroscopy method. The results are presented in color spaces such as CIE L*a*b* and L*C*h.

L*- skin brightness

a*- shift toward red or green

b*- shift toward yellow or blue

The results obtained enable a precise assessment of the degree of skin redness, the level of natural pigment (melanin) and skin gloss, providing objective parameters that characterize the skin.

Measurement	Erythema	Melanin	CIEL-L*	CIE-a*	CIE-b*	Chroma	Hue	Gloss
1	19,80	32,50	57,38	7,59	13,24	15,21	59,90	3,0
2	19,85	32,58	57,39	7,65	13,21	15,24	59,88	3,0
3	19,80	32,57	57,37	7,62	13,25	15,21	59,89	3,1
4	19,82	32,56	57,35	7,65	13,26	15,20	59,73	3,0
5	19,81	32,55	57,30	7,77	13,28	15,23	59,70	3,1

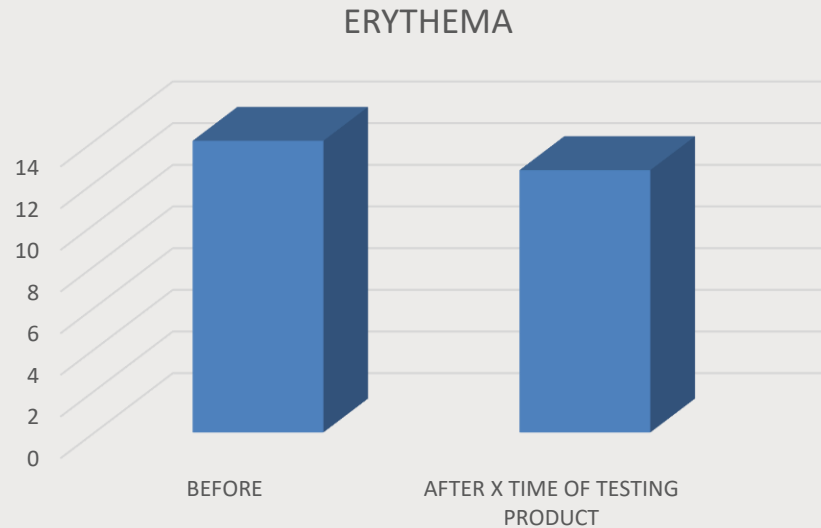

ERYTHEMA

The test is aimed at quantitative assessment of skin redness. The measurement is performed using an optical method based on the analysis of light reflection at different wavelengths. The results are presented as a percentage change in erythema values relative to the baseline, which allows for an objective assessment of the effects of using the tested product. Based on the analysis, it can be determined whether the **product reduces skin redness**.

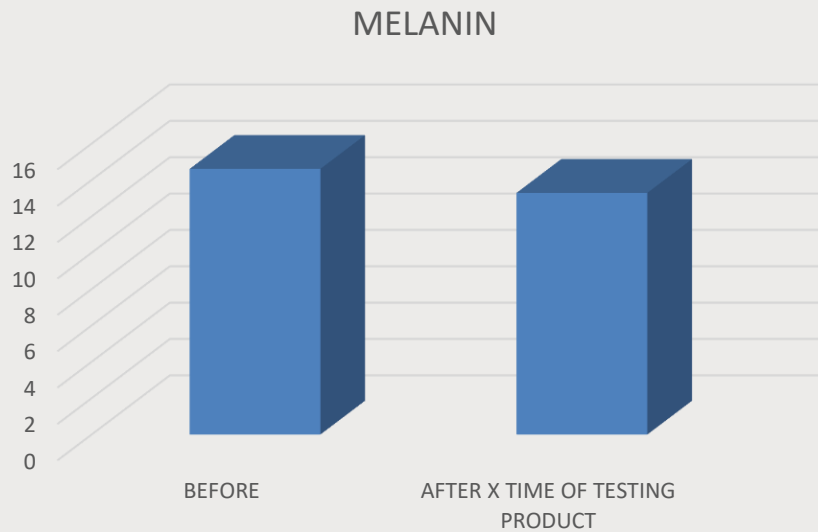

MELANIN

The melanin measurement probe is based on the reflectance spectrophotometry method, which involves emitting light of a specific wavelength onto the skin surface and analyzing the scattered and reflected light.

The method enables objective, quantitative assessment of skin pigmentation levels and monitoring of changes over time. The test is used to evaluate the effectiveness of cosmetic products that claim to lighten and improve skin tone uniformity.

SKIN GLOSS

The skin gloss test using the DermaLab Combo device is a modern, non-invasive method that enables an objective assessment of a cosmetic product's effect on skin luminosity and overall healthy appearance. The gloss parameter is particularly useful in evaluating products such as creams and serums, allowing for a precise analysis of their efficacy.

The method allows for the assessment of the immediate effect achieved directly after product application. The results obtained from the test confirm marketing claims such as:

- ✓ **gives the skin a radiant appearance**
- ✓ **gives the skin a natural glow (glow effect)**
- ✓ **improves skin brightness**

SKINFIBROMETER

Specialized device designed to measure tissue hardening and fibrosis. It enables quantitative assessment of superficial skin hardening and the upper layer of subcutaneous tissue. The result is given in newtons (N). It is used in testing the effectiveness of cosmetic products, in particular anti-cellulite and firming preparations. It allows:

- ✓ objectively assess the degree of hardening and fibrosis of the subcutaneous tissue
- ✓ verify the effect of the product on reducing the hardness of cellulite-related changes
- ✓ quantitatively assess the improvement in skin elasticity

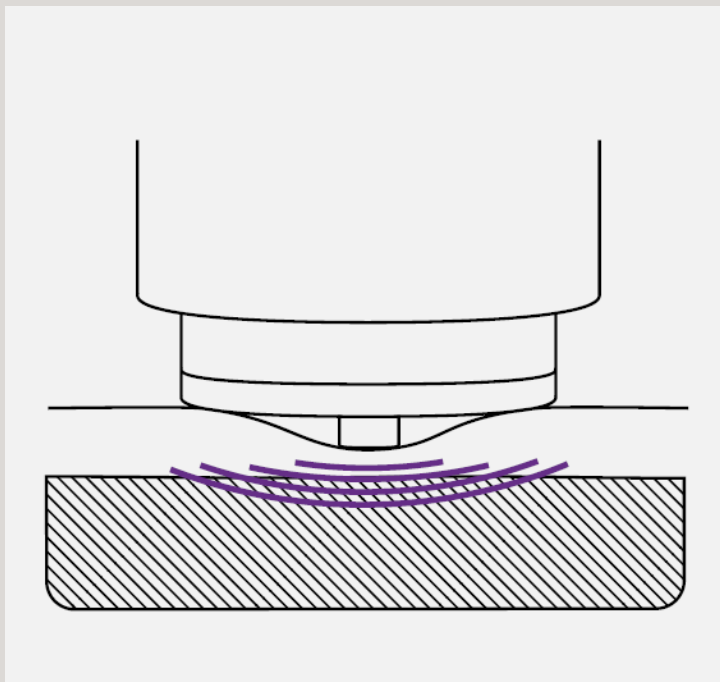

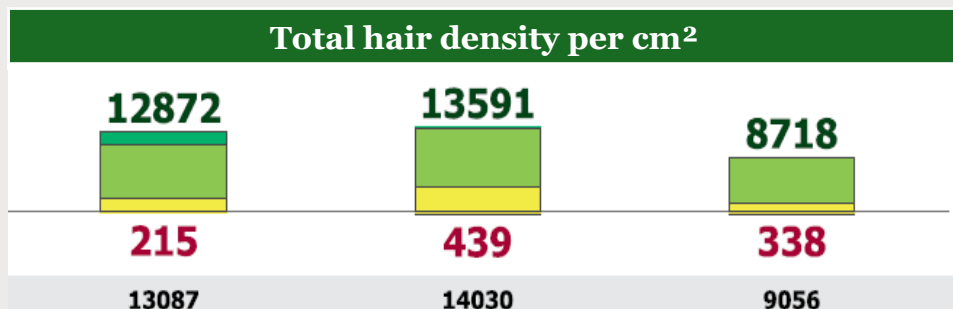
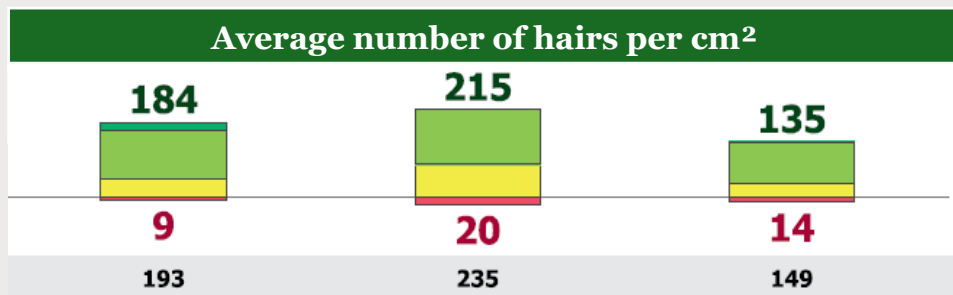

	Temporal	Vertex	Occipital
Terminal: Vellus Ratio	21.3:1	10.7:1	9.4:1
Average hairs per follicular unit	1.5	1.6	1.4
Average hair width	68.1	59.7	60.7
Follicle count	126.0	149.0	103.0
Interfollicular mean distance	1.08	1.02	1.18

HairMetrix is a videotrichoscope with AI-based analytical software that takes magnified images of the scalp and hair, and then automatically analyzes the parameters of the hair and hair follicles. Based on this, the following parameters can be determined:

- ✓ terminal: vellus ratio
- ✓ average interfollicular distance
- ✓ average hairs per follicular unit
- ✓ hair density
- ✓ hair thickness

The results obtained allow for a comparison of test results over time, enabling an assessment of the cosmetic product's effectiveness.

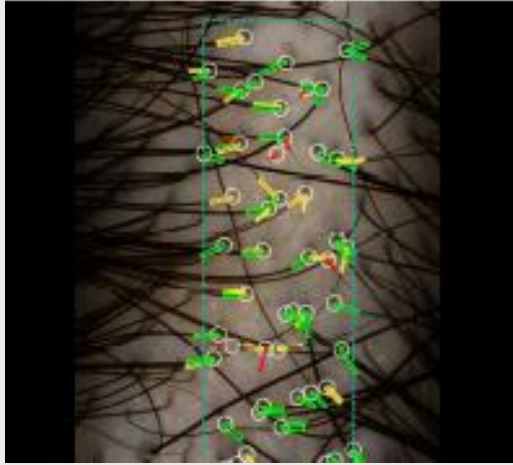

TERMINAL: VELLUS RATIO

This parameter measures the ratio of terminal hair (thicker, darker, and longer, indicative of mature and active hair follicles) to vellus hair (thin, short, and light-colored, typical of immature or regenerating hair).

Based on the results obtained, it is possible to confirm, among other things, claims regarding an **increase in the proportion of terminal hair** and a reduction in hair follicle miniaturization.

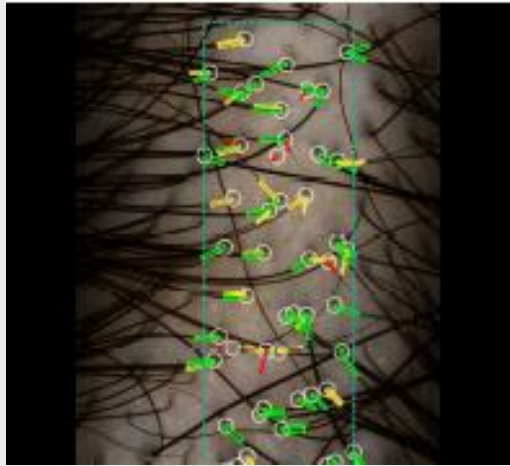

AVERAGE INTERFOLLICULAR DISTANCE

The average distance between adjacent hair follicles in the analyzed area of the scalp is determined. The analysis involves locating the hair follicles and calculating the average distance between them, which serves as an objective indicator of the **distribution and density of hair follicles**.

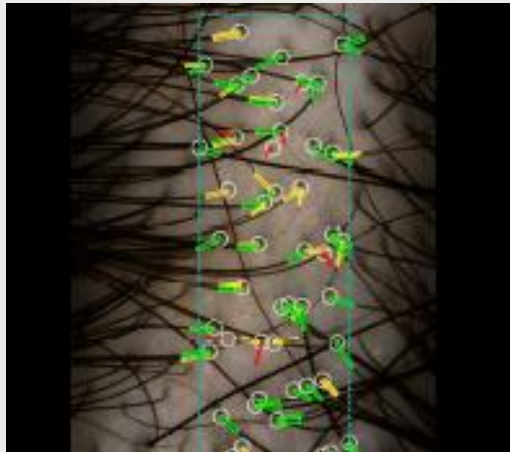

AVERAGE HAIRS PER FOLLICULAR UNIT

This parameter indicates the average number of hairs per single hair follicle. It is determined through a quantitative analysis that involves counting the number of hairs and the number of hair follicles in a defined area of the skin, followed by the calculation of the average value. A lower average number of hairs per follicular unit may indicate hair thinning and weakening, while **higher values are characteristic of normal, dense hair-bearing skin**.

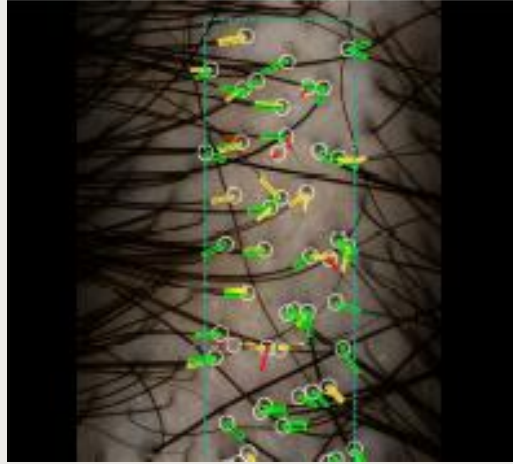

HAIR DENSITY

This allows for a precise assessment of the number of hairs in a specific area of the scalp. The result obtained includes the percentage change in hair density relative to the baseline value. The results obtained during the study confirm the **effectiveness of the product in increasing hair density** and reducing hair loss.

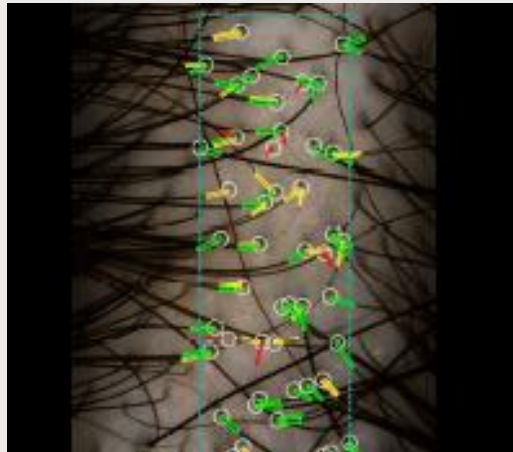

HAIR THICKNESS

The test involves measuring the diameter of a single hair, which allows for a precise assessment of its structure and thickness. The final result is presented as a percentage change in hair diameter relative to the baseline value. The parameter obtained allows for an objective determination and declaration of **improvement in hair thickness**.



Microphotography taken at 60x magnification.

CONDITION OF THE SCALP

The test provides an overall picture of the condition of the scalp. The analysis allows to determine the effectiveness of the product in terms of **cleansing and improving the condition of the scalp.**



Microphotography taken at 60x magnification.

KERATINIZATION

The test provides information on the condition and stage of scalp dandruff. The analysis can determine whether the product has **effectively reduced dandruff on the scalp.**



Microphotography taken at 60x magnification.

SENSITIVITY OF THE SCALP

The test involves determining the level of hypersensitivity, irritation, and redness on the scalp. The analysis allows us to verify whether a given product has a **soothing effect on the scalp**.



Microphotography taken at 60x magnification.

CONDITION OF HAIR FOLLICLES

The test involves assessing the patency and possible blockages of hair follicle outlets. The test results allow the **effectiveness of their cleansing** to be verified.

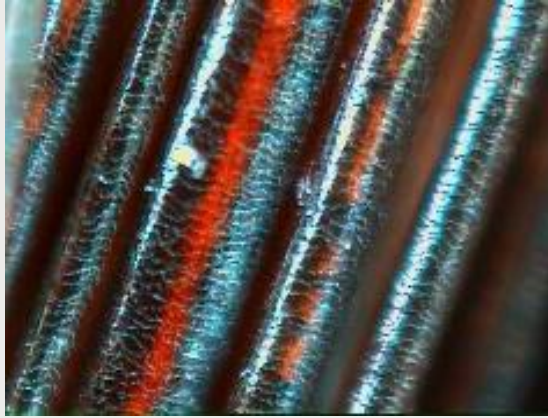

Microphotography taken at 500x magnification.

HAIR CUTICLE

The test allows to assess the structure and condition of the hair cuticle. The analysis carried out allows to determine the effectiveness of the product in **smoothing the hair cuticle and improving the overall condition.**

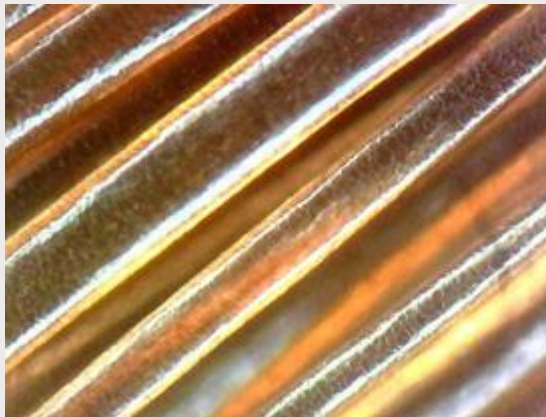

Microphotography taken at 500x magnification.

HEAT PROTECTION

The test allows the effectiveness of products protecting hair against damage caused by high temperatures when using hair styling devices to be assessed. Thermal protection aims to **minimize the negative impact of heat on the hair structure (hair cuticle).**



Microphotography taken using polarized light at 60x magnification.

CONDITION OF NAIL CUTICLES

The test of nail cuticles involves assessing the condition of the cuticles and the surrounding skin around the nail. Based on the results obtained, it is possible to confirm the effects of the product in terms of:

- ✓ improving the condition of nail cuticles
- ✓ smoothing nail cuticles



Microphotography taken using polarized light at 60x magnification.

CONDITION OF THE NAIL PLATES

Analysis of nail plates allows assessing their current condition and surface texture. Based on the results obtained, it is possible to visually verify the effectiveness of the product in terms of:

- ✓ improving the condition of nail plates
- ✓ reducing unevenness of nail plates



VISUALLY ASSESSMENT OF LIP ENHANCEMENT

The analysis is dedicated to lip augmentation products. The results of the study allow for:

- ✓ objective assessment of the product's effectiveness in lip augmentation
- ✓ documentation of the effects in visual form



VISUALLY ASSESSMENT OF TEETH WHITENING

Teeth whitening is assessed using the VITA 3D MASTER color chart, which enables precise and objective analysis of changes in enamel color. This tool can be used to determine the degree of teeth whitening. The test allows the **effectiveness of the whitening products** used to be monitored.

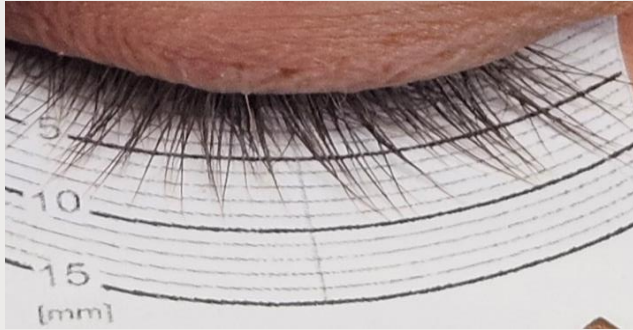

EYELASH GROWTH ANALYSIS

A precise test to assess the length of eyelashes. The measurement is taken using a specialized tape measure in millimeters (mm), which allows for an accurate and objective assessment of changes in hair length. As part of the test, photographic documentation is taken showing the condition of the eyelashes before and after a specified time of use of the product. This allows for a comparison of the effects and an assessment of the product's effectiveness.



VISUALLY ASSESSMENT EYEBROW DENSITY

A test designed to assess eyebrow density. The test involves taking photographs of the eyebrows before and after a specified period of use of the product. This allows for a **visual comparison of the effects of the product.**



DEGREE OF REMOVAL OF A COSMETIC PRODUCT USING A WOODS LAMP

The test is performed using a portable quartz lamp equipped with a special Wood's filter that emits long-wave ultraviolet light. This solution allows the detection of residues of products containing SPF filters on the skin surface. The washability of the product is assessed on a five-point scale.

The tests at **SKINLAB P.S.A** are conducted by a team of qualified specialists



The team consists of: Patrycja, Sylwia, Olga, Wiktoria, Jagoda, Aleksandra and Lidia.

SKINLAB P.S.A is a modern, dynamically developing research laboratory, created to provide comprehensive support to manufacturers of cosmetics, household chemicals, detergents, nutritional supplements, and chemical mixtures. Our mission is to confirm the **safety, quality, and effectiveness** of products that reach consumers.

At SKINLAB P.S.A., we support both start-ups and small businesses that are just starting out in the industry, as well as renowned brands and large corporations that launch hundreds of products every year. Together, we are building a future based on reliable research, transparency, and high safety standards. We ensure complete professionalism, objectivity, and confidentiality at every stage of cooperation. Our goal is to provide services that help **create proven, tested, and safe products**.

We invite to cooperate with SKINLAB!



MEMBER COMPANY
POLISH ASSOCIATION OF COSMETIC
AND DETERGENT INDUSTRY **PACDI**

